

ARM

DEVELOPMENT TRAINER KIT



PLUG & CODE



ON BOARD
PROGRAMMING



RTC



ON BOARD
MODBUS RTU

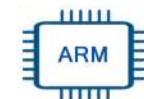

ARM 7
PROCESSOR





START YOUR EMBEDDED SYSTEM DESIGN JOURNEY TODAY..!

LPC2148 essential development features a plug and play design that makes it easy for connections and helps Students, hobbyists, enthusiasts and professionals to focus more on Program/application development. LPC2148 Trainer Kit equipped with on board IO's, communication interfaces & peripherals. It is really easy to design, experiment with, and test circuits without soldering. It's used in many educational institutions and R&D LAB across the world.

Board Features

- Plug & Play Interface Connectivity.
- Professional EMI/RFI Complaint PCB Layout Design.
- Modular Block design makes easy access & quick prototyping.
- FRC connectivity features minimize the connection error.
- High quality grade PCB with wooden enclosure.
- Stackable daughter board LPC2148 in - built CAN Module.
- On board debugging JTAG Option.
- Controller Area Network (CAN) transceiver.
- USB onboard programming.
- 8 interfacing LED's
- 1 * 4 interfacing keys.
- 4 * 4 interfacing keypad matrix.
- Two channel RS232 port for communication.
- 3 ADC potentiometer input interface.
- 16 * 2 LCD, OLED interface.
- 7 Seg Multiplexed Display.
- ON board Micro SD Card.
- ON/OFF slide switch, RDL bus.
- External jumper nodes.
- Reset button.
- Power plug - in DC Socket.
- Power supply indicator LED.
- Test led for Tx, Rx.
- 46 General purpose IO
- FT232RL USB communication
- 8 pin DIP switches.

ON BOARD DIY PROJECTS

- Digital clock using RTC DS1307 & 16x2LCD.
- Digital lock using Hex Keypad & 16x2LCD.
- Digital password enabled access control system.
- Temperature sensing & controlling relay.
- Temperature sensing & speed control of motor.
- Simple pulse input seven segment counter.
- Realtime Temperature sensing & Login to SD card.
- Data Login through RS232 serial interface with # deluminator.
- Modbus master / slave communication.
- Bluetooth controlled appliance through Relay
- Timer enabled Relay
- Motor controlling throught WiFi
- LED controlling through PC (USB Interface)
- 4 digit random number generator
- Graphic icon display using OLED
- Menu controller LED chases

DEVELOPMENT ENVIRONMENT





ABOUT LPC2148 DEVELOPMENT BOARD

The LPC2148 micro controllers are based on a 16/32 bit ARM7TDMI-SCPU with real time emulation and embedded trace support, that combine the micro controller with embedded high – speed flash memory ranging from 32kB to 512 kB. LPC2148 are ideal for applications. where miniaturization is a key requirement, such as a access control and point of sale. Serial communications interfaces ranging from a USB 2.0 Full-speed-device multiple UARTs, SPI, SSP to I2C-bus and on-chip SRAM of 8kB up to 40kB, make these devices very well suited for communication gateway and protocolconverters, soft meddem, voice recognition and low end imaging. providing both largebufer size and high processing power.

Scope of Learning Experiments:

- LED blinking
- 8 bit LED Left shift, Right shift and counting operation.
- Keypad interrupt interface
- 6*2 LCD interface
- Matrix Keypad Interface
- ADC & DAC interface
- Traffic Light Signal Interface
- 8 bit DIP switch interface
- 7 Segment interface
- Multi processing using Dual core ARM
- Interfacing SD card and handling file system with ARM using SPI and other method
- Interfacing sensor with & Data parsing using RESTful & Json protocol
- FTP Implementation
- L298 Driver for DC Motor and Stepper motor interface
- Communication using UART, I2C & SPI
- Buzzer, Relay interface
- RS485, RS232 serial communication
- ARM IO Interfacing with different sensor
- RTC DS1307I2C protocol interface
- AT24C04 EEPROM I2C protocol interface
- RF/WiFi Communication
- Temperature Sensor Interface

- Interfacing sensor with ARM and MQTT protocol Implementation
- Exploring MQTT Features Subscribe & Publish methods
- MQTT SSL certificate implementation - ARM
- Interfacing RS485 salve using MODBUS protocol
- Interfacing BLE & Data parsing using RESTful/Json/MQTT protocol
- OTA Implementation –ARM
- Implementation of FREE RTOS on ARM
- Exploring DMA features of ARM
- Text to speach Implementation
- Device control through Speech recognition & Alexa integration
- Appliance control through cloud platform using MQTT protocol
- Environment data like temp & humidity capturing using cloud platform
- Modbus RTU Communication and accessing data from Industrial PLC
- Wireless TCP/IP socket connection implementation using node and server architecture
- Exploring WiFi – MESH features
- BioMedical sensor kit integration and connecting IoT cloud platform for prediction
- Exploring OPC/UA server and client implementation
- implementation of ESP32 WEB server application



SPECIFICATION

MCU

- 16/32-bit ARM7TDMI-S microcontroller in a tiny LQFP64 package.
- In-System Programming (ISP)
- 40kB of on-chip static RAM
- 512kB of on-chip flash memory
- 10-bit DAC

HARDWARE

- **Interfaces:** SD card, UART, SPI, SDIO, I2C, LED PWM, Motor PWM, I2S, IR, pulse counter, GPIO, ADC.
- **Communication Interface:** RS232, RS485 (Modbus RTU), USB, SPI, I2C.

DISPLAY INTERFACE

- OLED 0.96"
- 16X2 LCD Display
- Seven Segment Display

KEYPAD INTERFACE

- 4X4 Hex Keypad
- 1X4 Menu Keypad

MEMORY INTERFACE

- SD Card Interface
- EEPROM AT24C08

DRIVERS, RELAY & BUZZER

- DC Motor/Stepper Motor
- Buzzer

ON BOARD SENSOR, TEXTING INPUT POT & SWITCHES

- 1X Temperature Sensor LM35
- 3X Analog Test POT
- 8X Selection DIP Switch

CONVERTER & ADAPTER INTERFACE

- Xbee Adapter
- 3.3V to 5V Level Converter

REAL TIME CLOCK (RTC)

- RTC DS1307

ON BOARD POWER POINTS

- 5V, 3.3V & GND

DIMENSION

- W 264 X L199 X H 60

ARM DEVELOPMENT TRAINER KIT BOARD NARRATION

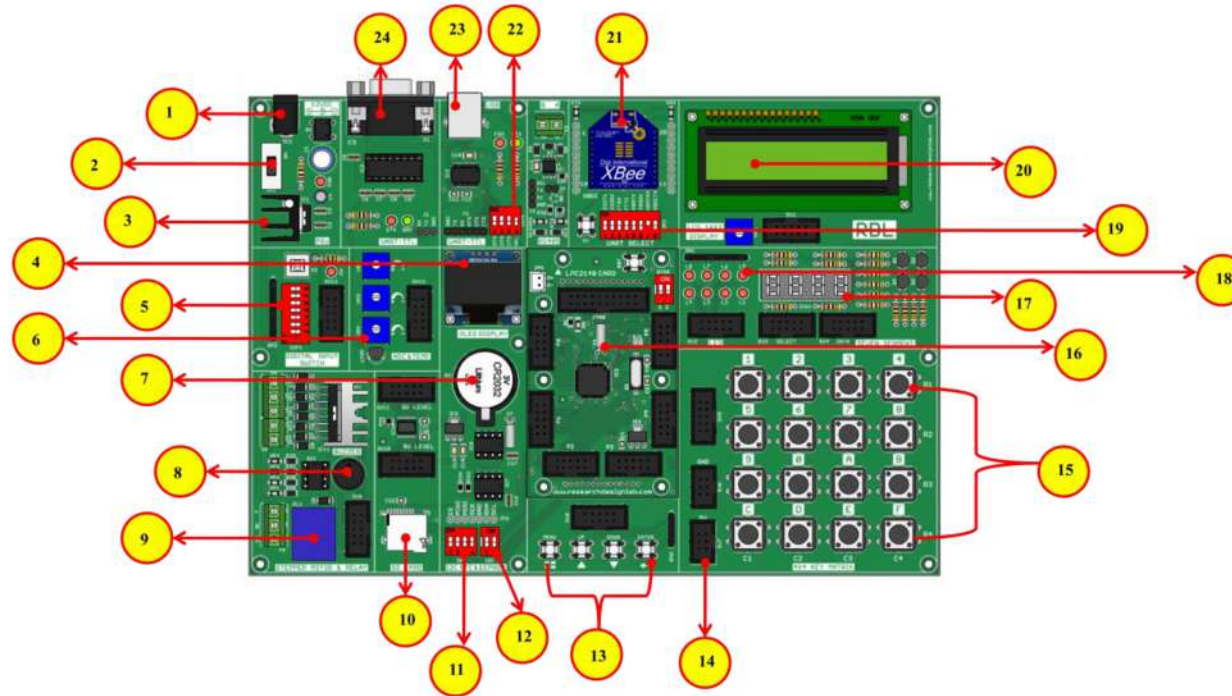

1. Power Supply	9. Relay	17. 7 Segment Display
2. Power ON Switch	10. SD Card Holder	18. 2*4 LED's
3. Heat Sink	11. Jumper Settings for I2C RTC	19. Jumper Settings for UART Selection Pin
4. ADC (Variable Resistor POT)	12. Jumper Settings for EEPROM	20. 16*2 LCD Display
5. OLED Display	13. 1*4 Keypad Switches	21. WiFi Module
6. Digital Input Switch	14. RDL Bus FRC Connector	22. Jumper Settings for UART TTL
7. RTC Battery	15. Keypad Matrix	23. USB Port
8. Buzzer	16. ARM LPC2148 Controller	24. DB-9 Serial Female Connector



APPLICATION WIRING DIAGRAM

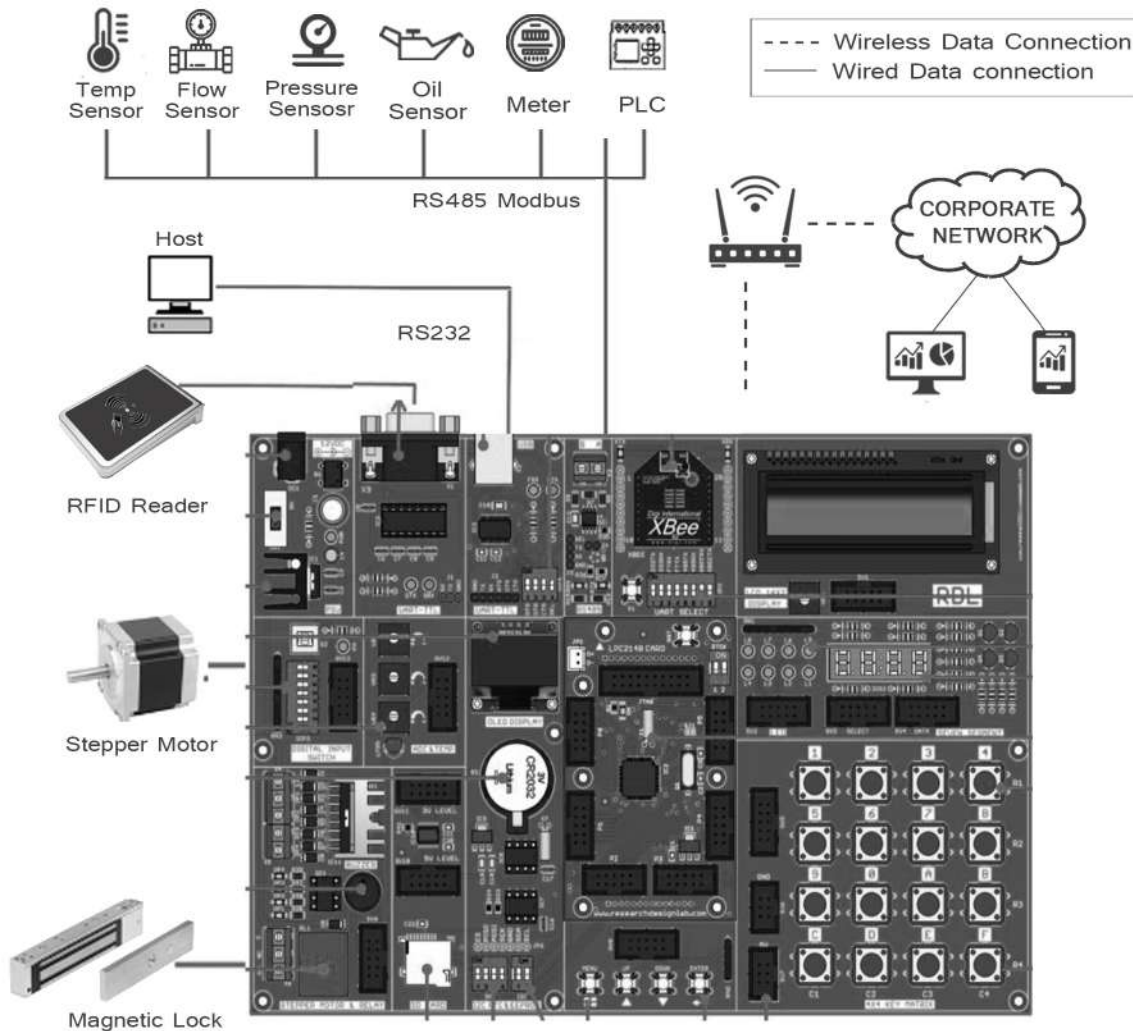

Quick Idea to Proof of Concept (POC)

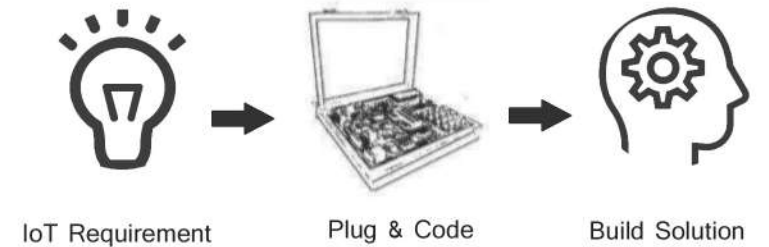

Package Includes

- ✓ Development Board with Wooden Enclosure
- ✓ USB Cable
- ✓ 12V 2A Adapter
- ✓ FRC Cable

NOTE: Xbee module is not included in the package

Optional OLED & SD Card module provided on this board. hobbyist / developer can make use of this module with their previous knowledge or open source community support and we do not have the support for the optional modules.



Note:

1. Unless otherwise specified, all parameters in this datasheet were measured at 25°C and 75% humidity.
2. All index testing procedures in this datasheet are based on our company's corporate standards.
3. We can offer product customization; please contact the sales team directly for more information.
4. Specifications are subject to change without prior notice:
5. For additional information on Product please refer to www.rdltech.in
5. Buy online @ www.researchdesignlab.com

RDL Technologies Pvt Ltd

Address: 5th Floor, Sahyadri Campus, Adyar, Mangaluru - 575007

Mob: +91 8088423347

Tel: +91 824 2988407

Email: sales@rdltech.in

www.rdltech.in